



## Short Communications

Adaptation and psychometric properties of *Lexington Attachment to Pets Scale*: Brazilian version (LAPS-B)

Nathália Saraiva de Albuquerque<sup>a</sup>, Dalton Breno Costa<sup>b,1</sup>, Gabriel dos Reis Rodrigues<sup>c</sup>, Natália Silva Sessegolo<sup>a</sup>, Carmen Moret-Tatay<sup>d,\*</sup>, Tatiana Quarti Irigaray<sup>a</sup>

<sup>a</sup> Department of Psychology, Pontifical Catholic University of Rio Grande do Sul (PUCRS), Porto Alegre, Rio Grande do Sul, Brazil

<sup>b</sup> Department of Psychology, Federal University of Health Sciences of Porto Alegre (UFCSA), Porto Alegre, Rio Grande do Sul, Brazil

<sup>c</sup> Department of Psychology, Federal University of Rio Grande do Sul (UFRGS), Porto Alegre, Rio Grande do Sul, Brazil

<sup>d</sup> Department of Psychology, Universidad Católica de Valencia San Vicente Mártir (UCV), Valencia, Spain

## ARTICLE INFO

## Article history:

Received 24 August 2021

Revised 14 November 2022

Accepted 8 December 2022

Available online 13 December 2022

## Keywords:

LAPS

Attachment

Human-animal interaction

Psychometric properties

Cross-cultural adaptation

## ABSTRACT

Society has increasingly come to appreciate the relationship between people and pets, and therefore, the demand for research into this subject has also been growing. In Brazil, tools designed to assess the human-animal relationship are still scarce, and so far, there is no tool, adapted for the Brazilian context, designed to evaluate the bond between people and their animals. The Lexington Attachment to Pets Scale (LAPS) is a scale that aims to measure the degree of attachment that an owner has for their pet. It is one of the most used tools to assess the emotional bond between people and their animals. The aim of this study, therefore, was to translate, cross-culturally adapt, and evaluate the psychometric properties of the LAPS for the Brazilian population (LAPS-B). For this purpose, confirmatory factor analysis and reliability tests were conducted on a sample of 2526 dog and cat owners from all over the country, of whom 81.87% were female and who had a mean age of 33.85 years old (standard deviation = 12.81). The comparison between the models showed that the 3-factor correlated model and the hierarchical model had better metrics than the others, and that the hierarchical model was the most suitable. In conclusion, the Brazilian version of the LAPS is a reliable measure of the attachment to dogs or cats, and can be used to assist research and studies that address the human-animal relationship. Future research should investigate the psychometric properties of the scale on other animal species.

© 2022 Elsevier Inc. All rights reserved.

## Introduction

There is increasing interest in the academic field in investigating the relationship between people and their pets, and the degree of attachment to the animal seems to be an important variable that needs to be considered in any investigation on this topic (Teo and Thomas, 2019). Currently, there are several scales designed to measure the degree of attachment that the owner has for their pet. These include: the Pet Attachment Survey, which is used to assess the human attachment to dogs and cats through

physical interaction (Relationship Maintenance) and through emotional importance (Intimacy) (Holcomb et al., 1985); the Pet Attachment Questionnaire, which is organized along 2 orthogonal dimensions: attachment anxiety and avoidance (Zilcha-Mano et al., 2011); the Owner Pet Relationship Questionnaire, which is based on Bowlby's attachment theory that assesses whether someone perceives the human-animal bond as reciprocal and emotionally supportive (Winefield et al., 2008); the Pet Relationship Scale, which measures feelings of affection and activity regarding pets (Kafer et al., 1992); the Companion Animal Bonding Scale, which is a behavioral scale that describes child-animal activities (Poresky et al., 1987); and the Lexington Attachment to Pets Scale (LAPS), which is used to assess the strength of a person's attachment to his or her pet (Johnson et al., 1992). The LAPS is one of the most used of these scales to assess people's emotional bonds with their pets (Ramírez et al., 2014). The LAPS was developed from 2 attachment scales created in previous studies by the same research team,

\* Address for reprint requests and correspondence: Carmen Moret-Tatay, Department of Psychology, UCV, Avenida de la Ilustración no2, Burjassot, Valencia, 46100, Spain.

E-mail address: [mariacarmen.moret@ucv.es](mailto:mariacarmen.moret@ucv.es) (C. Moret-Tatay).

<sup>1</sup> Present address: Department of Computer Science University of North Carolina at Greensboro (UNCG), 1400 Spring Garden St, Greensboro, NC 27412.

with the inclusion of elements from the Companion Animal Bonding Scale (Poresky et al., 1987), the Pet Attitude Scale (Templer et al., 1981), and the Pet Attitude Inventory (Wilson et al., 1987).

The LAPS was initially created with 3 orthogonal factors. The first factor is called general attachment and measures the strength of the bond that someone has with their animal. The second factor, called substitution of people, refers to the animal playing a central role in the life of the owner. The third factor concerns the status of the pet; it is related to the importance that the animal has in their owner's life. This factor is called the right and welfare of animals (Johnson et al., 1992). However, in the literature, LAPS is not used as 3 unrelated subscales, but rather as a single dimensional scale. In relation to how it has been used, the total LAPS score (sum or mean of 23 items) has been applied to studies on human-animal interaction (Antonacopoulos and Pychyl, 2010; Miltiades and Shearer, 2011; Rothgerber and Mican, 2014; Reevy and Delgado, 2015), and this total score is usually called "pet attachment."

As the demand for research into human-animal interaction has been growing, it is important to have tools designed to assess the human-animal relationship for the Brazilian context. To date, there are no Brazilian studies that have translated, cross-culturally adapted, and validated the LAPS. In view of the potential to use this scale in research on this topic, this study aimed to translate, adapt, and evaluate the psychometric properties of the LAPS for the Brazilian population, based on the original version of the tool (Johnson et al., 1992). To this purpose, we investigated its psychometric properties and validity evidence based on its content and internal structure through a review by judges, confirmatory factor analysis, and reliability tests.

## Materials and methods

The method used in this study, to carry out the process of adapting and validating the LAPS scale for Brazil, was divided into 2 stages. In the first stage, the LAPS was translated and adapted for the Brazilian population, and in the second, the psychometric properties were evaluated. These stages are described below:

### Stage 1: Translation and cross-cultural adaptation of the LAPS

The translation was carried out according to a combination of procedures recommended in the literature (Muñiz et al., 2013; Hernández et al., 2020). First, the original authors of the LAPS were contacted by email to obtain their authorization to translate the tool, and, after this, we began the translation and cross-cultural adaptation process. Two independent translators (T1 and T2) produced 2 versions of the tool in Portuguese. Both translators were Brazilian and fluent in the English language. These versions were compared and combined by a third independent translator (T3) to produce a single version. This T3 translator was a psychologist with a broad command of the English language (Table A1). Subsequently, this final Portuguese version was reviewed by the target audience, to check that the Brazilian population could understand the wording and meaning of the items.

After the target audience (10 Brazilian pet owners recruited through social media) had reviewed it, the tool was reverse translated independently (T4). This T4 translation was done by a Brazilian with a qualification in English. The reverse translation was sent to the original authors, who were content that the content of the Portuguese version was equivalent to the original content. The new version was used in a pilot study involving 10 professional workers (5 veterinarians and 5 psychologists), who assessed the level of understanding and acceptability of the items using an online research platform (Qualtrics), and answered a closed question (yes

or no) that asked, "is the overall meaning of this item understandable?". Besides this, the assessors could also suggest changes to the items.

Out of the changes suggested by the assessors, the suggestions for items 8 (replacing the word "think" with the word "understand") and 10 (the word "know" was changed to the word "feel") were adopted, because these changes helped Brazilians to understand these. The research team discussed the other suggested changes and decided not to adopt them, because they would change the original meaning of the items in the scale. The scores of the assessors were used to calculate the content validity index (CVI), which indicated that all the items in the scale were satisfactory.

Finally, after some further adjustments from discussions between the Brazilian authors, we created a final Portuguese version of the LAPS. This final version was used to survey the general population in order to validate it. The final Portuguese version of the LAPS and its CVIs can be viewed in Appendix A. The full LAPS-Brazilian version (LAPS-B) is presented in Appendix B, along with guidelines for using the tool.

### Stage 2: Assessment of the psychometric properties of the LAPS-B

#### Participants

The composition of the sample was based on the guidelines provided for this field, which suggest 10 participants per item in the tool being assessed (Urbina, 2007). Therefore, we calculated that the sample should have at least 230 participants. We included everyone over 18 years old who owned a dog or a cat in the survey. Any participants who failed to complete the LAPS-B fully were excluded from the study. The final sample for this study consisted of 2526 individuals from all over Brazil, the majority (52.14%) from the Southern region. The majority (2068; 81.87%) of the participants were female and the mean age was 33.85 years old (standard deviation = 12.81), ranging from 18 to 76 years old. The participants were asked to choose a favorite animal from those they owned to answer the questionnaire on, and 1577 (62.43%) participants chose a dog as their favorite animal. This and the rest of the sociodemographic information are available in Table 1 below.

#### Procedure

The participants were recruited through marketing campaigns and posts on social media (invitations through Facebook, Instagram, etc.), as well as emails that were sent to universities in different regions of Brazil, especially to ask people to answer an online questionnaire, through the Qualtrics platform. The research link remained active from the beginning of September to the end of November 2020.

#### Measures

**Sociodemographic data questionnaire.** This was designed to collect data on the sociodemographic character of the sample and matters related to the animals.

**The LAPS-B.** The LAPS-B is designed to measure the degree of attachment that owners have for their pets. It is a useful indicator of attachment in relation to both dogs and cats. This scale consists of 23 items that are presented in a 4-point Likert scale format, ranging from 0 (strongly disagree) to 3 (strongly agree). The authors of the original scale reported a Cronbach's alpha of 0.93 for these 23 items (Johnson et al., 1992). Table B1 shows the Brazilian version that the participants answered in this study.

#### Data analysis

The data were analyzed using R software (R Core Team, 2020). Qualitative variables were described using absolute (n) and relative

**Table 1**  
Participants' sociodemographic data

| Variable              |                                     | n     | %     |
|-----------------------|-------------------------------------|-------|-------|
| Country region        | South                               | 1317  | 52.14 |
|                       | Southeast                           | 770   | 30.48 |
|                       | Northeast                           | 244   | 9.66  |
|                       | Midwest                             | 86    | 3.40  |
|                       | North                               | 75    | 2.97  |
|                       | Distrito federal (federal district) | 34    | 1.35  |
| Education level       | Elementary school (incomplete)      | 14    | 0.55  |
|                       | Elementary school (complete)        | 23    | 0.91  |
|                       | High school (incomplete)            | 47    | 1.86  |
|                       | High school (complete)              | 293   | 11.60 |
|                       | Undergraduate (incomplete)          | 794   | 31.43 |
|                       | Undergraduate (complete)            | 549   | 21.73 |
|                       | Graduate                            | 806   | 31.91 |
| Marital status        | Single                              | 1404  | 55.58 |
|                       | Married /stable union               | 937   | 37.09 |
|                       | Divorced/separated                  | 156   | 6.18  |
|                       | Widow(er)                           | 29    | 1.15  |
| Who do you live with? | Alone                               | 327   | 13.00 |
|                       | With relatives, friends or others   | 2,199 | 87.00 |
| Pets                  | I only have dogs                    | 1,264 | 50.04 |
|                       | I only have cats                    | 635   | 25.14 |
|                       | I have dogs and cats                | 627   | 24.82 |

(%) frequencies and quantitative variables were described using the first quartile (Q1), mean (M), standard deviation, median (Mdn), and third quartile (Q3). The univariate distribution of the investigated variables was analyzed using the Shapiro-Wilk test, adopting a significance level of 0.05. All variables in this study presented a distribution considered as being non-normal. The Mann-Whitney U test was used to verify the existence of significant differences between groups.

Different factorial structures for the LAPS-B were tested, taking into account the studies previously carried out on the scale using the lavaan package (Rosseel, 2012). We tested the following models: 3 correlated factors (1), unifactorial (2), 3 independent scales (3), and hierarchical model (4). The measures adopted to assess the adequacy criteria were the ratio between the chi-square ( $\chi^2$ ) and the degrees of freedom (df), the comparative fit index (CFI), the Tucker-Lewis index (TLI), the root mean square approximation of error (RMSEA), and the standardized root mean square residual (SRMR). We used the reference values recommended by Hu and Bentler (1999) and Brown (2015), where the CFI and TLI must have values greater than 0.95, while the RMSEA must present a value of less than 0.08 and the SRMR value must be less than 0.06. Diagonally weighted least square was used to extract the factorial solutions. This estimator was chosen because, compared to the weighted least squares mean adjusted (WLSM) and weighted least squares mean and variance adjusted (WLSMV), it is superior at calculating the parameters and adjustment indices in CFAs with

ordinal data (DiStefano and Morgan, 2014). We believe that other studies on the LAPS that tested the same models in this study observed poor goodness-of-fit indices because they used ML instead of WLSMV or diagonally weighted least squares. These are more appropriate estimators for modeling, when using ordinal data.

We assessed the internal consistency of the factors using the Cronbach's alpha and McDonald's omega coefficients, both with a 95% confidence interval. We considered that the values for Cronbach's alpha had to be at least 0.7 (Terwee et al., 2007) to be satisfactory, and that the values for McDonald's omega had to be between 0.7 and 0.9 to be acceptable (Ventura-León and Caycho-Rodríguez, 2017).

## Results

### Factor structure

The adjustment measures for the models are presented in Table 2. We can see that model 1 (3 correlated factors) and the hierarchical model have equivalent metrics. At the same time, it should be noted that model 1 and the hierarchical model presented better metrics than model 2 (1-factor model). The results of model 1 and the hierarchical model indicated a satisfactory fit for the model, based on the adequacy criteria of the CFI, TLI, RMSEA, and SRMR.

It should be noted that the goodness-of-fit indices of the independent models are better than the unifactorial and hierarchical models. However, retaining a factorial solution with three independent scales is not the current approach for the LAPS, whose 23 items have been analyzed unifactorially (Johnson et al., 1992; Antonacopoulos and Pychyl, 2010; Miltiades and Shearer, 2011; Miranda, 2011; Ramos et al., 2013; Rothgerber and Mican, 2014; Reevy and Delgado, 2015). Furthermore, the LAPS-B factors correlate well ( $r > 0.84$ ), to the extent that it makes no sense to examine the LAPS-B using only three independent factors.

Therefore, as there is a high degree of correlation between the 3 factors, the fact that LAPS is based on a general score, and the persistence in characterizing the scale as retaining 3 factors, the most appropriate model is the hierarchical model (Figure).

We compared the sex and housing variables to analyze their relationship with the total LAPS-B score. Women were significantly more attached to their pets than were men ( $U = 590.031$ ,  $P < 0.001$ ), with a median of  $Mdn = 58.00$  and  $Mdn = 55.00$ , respectively. This difference, however, had a weak effect size ( $r = -0.16$ ). Participants who reported that they lived alone had significantly higher attachment scores than those who lived with family, friends, or others ( $U = 391.869$ ,  $P = 0.008$ ), having median scores of  $Mdn = 58.00$  and  $Mdn = 58.00$ , respectively. However, the effect size presented was also weak ( $r = -0.05$ ).

**Table 2**  
Goodness-of-fit indices for the factorial models tested

| Models                 | $\chi^2$ | df  | RMSEA (90% C.I.)    | TLI  | CFI  | SRMR  |
|------------------------|----------|-----|---------------------|------|------|-------|
| Model 1                | 2917.91  | 227 | 0.069 (0.066–0.071) | 0.97 | 0.98 | 0.065 |
| Model 2                | 3473.01  | 230 | 0.075 (0.073–0.077) | 0.97 | 0.97 | 0.073 |
| Model 3                |          |     |                     |      |      |       |
| General attachment     | 469.51   | 44  | 0.062 (0.057–0.067) | 0.99 | 0.99 | 0.056 |
| Substitution of people | 156.88   | 14  | 0.064 (0.055–0.073) | 0.98 | 0.99 | 0.046 |
| Animal rights          | 27.14    | 5   | 0.042 (0.027–0.058) | 0.99 | 0.99 | 0.032 |
| Hierarchical model     | 2917.91  | 227 | 0.069 (0.066–0.071) | 0.97 | 0.98 | 0.065 |

Note. Model 1 = model with 3 correlated factors; Model 2 = one-factor model; Model 3 = model with 3 unrelated factors (original model by Johnson et al., 1992; see also Miranda, 2011; Ramírez et al., 2014); Hierarchical Model = model with 3 factors and one hierarchical factor (bond). The factor loadings of the hierarchical model can be seen in Figure. The absolute magnitudes of the factor loadings ranged from 0.42 to 0.92, the item with the lowest factor loading was item 9 ("I love my pets because they never judge me") from the "substitution of people" factor.

**Table 3**  
Description of the scores obtained by the LAPS-B participants based on chosen animal

| LAPS-B                 | Chosen animal | Q1    | M/SD        | Mdn   | Q3    | P    |
|------------------------|---------------|-------|-------------|-------|-------|------|
| General attachment     | Dog           | 27.00 | 29.10/4.23  | 30.00 | 32.00 | 0.73 |
|                        | Cat           | 28.00 | 28.89/4.68  | 30.00 | 32.00 |      |
|                        | All           | 27.25 | 29.02/4.41  | 30.00 | 32.00 |      |
| Substitution of people | Dog           | 12.00 | 14.50/4.10  | 15.00 | 18.00 | 0.47 |
|                        | Cat           | 11.00 | 14.30/4.30  | 15.00 | 18.00 |      |
|                        | All           | 12.00 | 14.43/4.18  | 15.00 | 18.00 |      |
| Animal rights          | Dog           | 11.00 | 12.02/2.53  | 13.00 | 14.00 | 0.26 |
|                        | Cat           | 11.00 | 12.10/2.62  | 13.00 | 14.00 |      |
|                        | All           | 11.00 | 12.05/2.56  | 13.00 | 14.00 |      |
| Bond                   | Dog           | 51.00 | 55.63/9.46  | 58.00 | 63.00 | 0.83 |
|                        | Cat           | 51.00 | 55.30/10.13 | 58.00 | 63.00 |      |
|                        | All           | 51.00 | 55.50/9.72  | 58.00 | 63.00 |      |

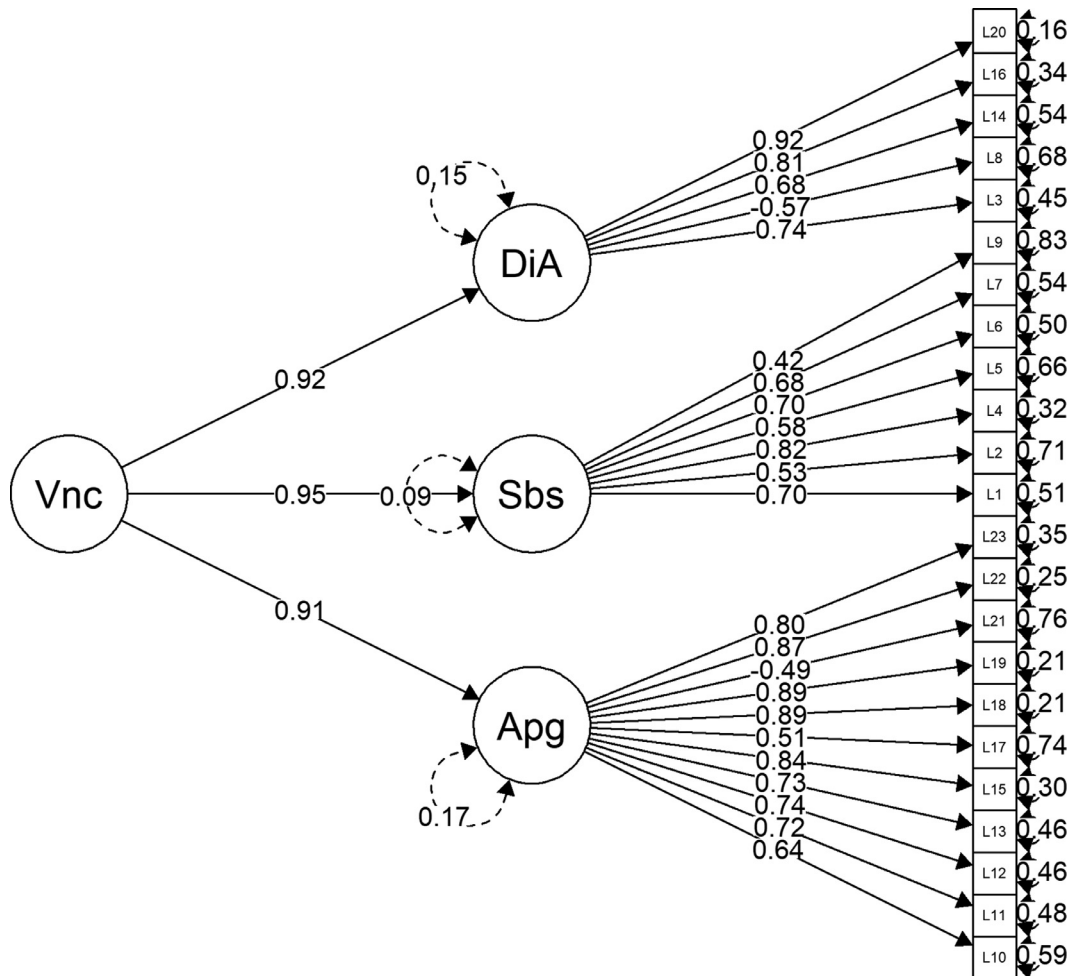

**Figure.** Factorial loadings for the 23 LAPS-B items in the hierarchical model. Note. DiA = animal rights, Sbs = substitution of people, Apg = general attachment, Vnc = pet bond. Figure was created using the package semPlot.

**Discussion**

The aim of this study was to translate, cross-culturally adapt, and assess the psychometric properties of the LAPS for the Brazilian population. Although this scale has previously been used in studies in Brazil (Ramos et al., 2013; Martins et al., 2014), no study, at the time of writing this article, has been found to have adapted it and validated it for the Brazilian context, using a rigorous methodology. After the translation process, we found that all items in the scale had a CVI over 0.80, which is higher than what is considered a minimum expected value (Hutz et al., 2015); therefore, no item was excluded from the LAPS-B. The translation

of items 8 and 10 was modified to ensure the statement was easier to understand. The CVIs of each item indicated that the items in the Brazilian version were equivalent and that there was agreement between the evaluators (Table A1).

When we investigated the psychometric properties, we found that the theoretical model of 3 correlated factors and the hierarchical model presented a better fit when compared to the 1-factor model. This model does not correspond to the 3 independent components model proposed by the authors of the original scale (Johnson et al., 1992), but it does accord with the interpretation of Johnson et al. (1992) and other works on interpreting a general LAPS score (Johnson et al., 1992; Antonacopoulos and Pychyl, 2010;

Miltiades and Shearer, 2011; Ramos et al., 2013; Miranda et al., 2014; Rothgerber and Mican, 2014; Reevy and Delgado, 2015).

The factorial structure of LAPS was the focus of one study (Zaparanick, 2008), which tested a 3-factor solution for LAPS using the maximum likelihood (ML) extraction method. Five items were excluded before the confirmatory factor analysis as they presented a skewness greater than 1. The results suggested that the model was a poor fit:  $\chi^2 = 4130.242$ ,  $df = 264$ ,  $CFI = 0.862$ ,  $TLI = 0.840$ , and  $RMSEA = 0.063$ . Also relating to the factor structure of the LAPS, Miranda (2011) performed a principal component analysis with varimax rotation on a Portuguese sample. This was the same procedure used by the original authors of the scale (Johnson et al., 1992). The final solution had 3 components: attachment, proximity, and importance in the life of the owner. Furthermore, the LAPS adaptation study for Mexico ( $n = 152$ ) tested 3 different factor solutions, concurrently: 1 with 3 correlated factors, a unifactorial structure and the suggestion of Johnson et al. (1992), 3 uncorrelated subscales. The extraction method was not reported. The best indices were found when estimating 3 subscales separately. The authors suggest, however, that the scale may be unidimensional, although they did argue that better indices for the 1-factor solution might be found with a larger sample (Ramírez et al., 2014). Therefore, there is a divergence in the literature on the factor structure of the LAPS. Although the independent models have shown better goodness-of-fit indices, in this study, we have suggested retaining the hierarchical model, in line with what has already been produced using the LAPS. In this model, we theorized that the “bond with the pet” factor was the hierarchical factor that influenced general attachment, people substitution, and animal rights.

Overall, we obtained good evidence of validity for the internal structure of the LAPS-B. Moreover, it should be noted that the value obtained for the “substitution of people” factor in the McDonald’s omega test (0.66) did not achieve the reference value, as indicated in the specific literature (Ventura-León and Caycho-Rodríguez, 2017). This may have been because this factor included the item that had the lowest factor loading among all the items in the scale (item 9). However, Cronbach’s alpha coefficients did achieve satisfactory values for all factors (Terwee et al., 2007).

Most participants chose dogs as their preferred animal when answering the LAPS-B (62.43%). This result is similar to the original version, where 63% of respondents also chose dogs as their favorite (Johnson et al., 1992). However, there were no significant difference in “bond” scores between people who chose dogs and those who chose cats. Although the results of the original version showed that people who chose dogs as their favorite pet had a greater bond with their animal than those who chose cats (Johnson et al., 1992), other studies that have used the LAPS found results similar to those in this study. This suggests that the type of favorite animal does not affect the LAPS score (Bagley and Gonsman, 2005; Miranda, 2011; Reevy and Delgado, 2015).

In relation to the sex of the participants, women showed a greater degree of attachment to animals compared to men. However, this difference had a weak effect size, which suggests that the degree of bonding does not differ between the sexes. Although the research by Bagley and Gonsman (2005) corroborates this finding, other studies have shown that women are more attached to their animals than men, which indicates that this variable is related to attachment to the pet (Johnson et al., 1992; Miranda, 2011; Martins et al., 2013; Reevy and Delgado, 2015; Joseph et al., 2019). This divergence may be due to the way in which the participants were recruited. In this study, the sample selection method was based on convenience, using advertisements on social media to notify pet owners about the research, and it is possible that people who were interested in answering the questionnaire already had a greater attachment to their animals, with no difference between the sexes.

However, some of these studies did not mention any effect size (Miranda, 2011; Martins et al., 2013), which does raise the hypothesis that men and women may be equally attached to their pets.

In this study, individuals who lived alone had higher bonding scores compared to those who lived with family, friends, or others. However, the effect size of this difference was weak. Although other studies that have used the LAPS did not address this specific issue, some of the research indicates that single individuals have a greater bond with their pet than those who are married (Johnson et al., 1992; Joseph et al., 2019). Other studies, however, have found no differences in the degree of bonding, between married and single people (Bagley and Gonsman, 2005; Miranda, 2011). According to the research by Johnson et al. (1992), individuals with few social relationships have higher scores for bonding with their animals. This suggests that people’s social relationships may be more relevant to their bond with the animal, than variables such as housing or marital status.

In terms of the limitations on this study, we should mention that the LAPS-B was only adapted for owners of dogs and cats and did not include people who have other species of pets. It is recommended that future studies should include other animal species when using the LAPS-B, so that these can be compared to the results for dogs and cats. In addition, it is important to obtain other types of validity evidence, such as convergent validity, in order to correlate this scale with other attachment scales and with tools that assess other variables.

## Conclusions

Therefore, we conclude that the LAPS-B is an adequate tool for measuring the attachment between people and their dogs and cats in the Brazilian context, and that the hierarchical model is appropriate, as it is possible to use it in research into human-animal interaction. The use of this tool, as adapted and with sufficient evidence of validity, can help with research in this area in Brazil and help with assessing the degree of attachment of owners to their animals. This can improve the quality of these human-animal relationships, which will benefit both the animals and the people.

## Authorship statement

The idea for the paper was conceived by Nathália S. Albuquerque, Dalton B. Costa, and Tatiana Q. Irigaray. The experiments were designed by Nathália S. Albuquerque, Dalton B. Costa, and Tatiana Q. Irigaray. The data were collected by Nathália S. Albuquerque, Dalton B. Costa, and Natália S. Sessegolo. The data were analyzed by Dalton B. Costa and Gabriel R. Rodrigues. The paper was written by all authors.

## Acknowledgments

The authors thank the Coordination for the Improvement of Higher Education Personnel (CAPES) and the National Counsel of Technological and Scientific Development (CNPq) for their financial support.

## Ethical considerations

This study was approved by the Research Ethics Committee of the Pontifical Catholic University of Rio Grande do Sul (PUCRS) under the following number: 36641120.3.0000.5336. All participants voluntarily agreed to participate in the research by agreeing to a Free and Informed Consent Form (FICF).

## Conflict of interest

The authors declare there are no conflicts of interest.

**Appendix A. Adaptation of Items to the Brazilian Version**

Table A1

**Table A1**

Original items and final adapted Brazilian items with their respective content validity index (CVI).

| Original  | Final adapted version  | CVI |
|---|--|-----|
| 1. My pet means more to me than any of my friends                                       | 1. Meu animal de estimação significa mais para mim do que quaisquer dos meus amigos.   | 1   |
| 2. Quite often I confide in my pet.   | 2. Eu costumo confiar no meu animal de estimação.  | 1   |
| 3. I believe that pets should have the same rights and privileges as family members     | 3. Eu acredito que os animais de estimação devem ter os mesmos direitos e privilégios do que membros da família.                 | 1   |
| 4. I believe my pet is my best friend.  | 4. Eu acredito que meu animal de estimação é o meu melhor amigo.   | 1   |
| 5. Quite often, my feelings toward people are affected by the way they react to my pet. | 5. Frequentemente, meus sentimentos em relação às pessoas são afetados pela maneira como elas reagem ao meu animal de estimação. | 1   |
| 6. I love my pet because he/she is more loyal to me than most of the people in my life. | 6. Eu amo o meu animal de estimação porque ele é mais leal a mim do que a maior parte das pessoas em minha vida.                 | .80 |
| 7. I enjoy showing other people pictures of my pet.                                     | 7. Eu gosto de mostrar fotos do meu animal de estimação para outras pessoas.   | 1   |
| 8. I think my pet is just a pet.  | 8. Eu entendo que o meu animal de estimação é apenas um animal de estimação.   | 1   |
| 9. I love my pet because it never judges me.  | 9. Eu amo meu animal de estimação porque ele nunca me julga.   | 1   |
| 10. My pet knows when I am feeling bad.   | 10. Meu animal de estimação sente quando eu estou me sentindo mal.   | 1   |
| 11. I often talk to other people about my pet.  | 11. Eu costumo falar com outras pessoas sobre meu animal de estimação.   | 1   |
| 12. My pet understands me.  | 12. Meu animal de estimação me entende.  | 1   |
| 13. I believe that loving my pet helps me stay healthy.                                 | 13. Eu acredito que amar meu animal de estimação me ajuda a me manter saudável.  | 1   |
| 14. Pets deserve as much respect as humans do.  | 14. Os animais de estimação merecem o mesmo respeito que os humanos.   | 1   |
| 15. My pet and I have a very close relationship.  | 15. Eu e meu animal de estimação temos uma relação muito próxima.  | 1   |
| 16. I would do almost anything to take care of my pet.                                  | 16. Eu faria qualquer coisa para cuidar do meu animal de estimação.  | 1   |
| 17. I play with my pet often.   | 17. Eu brinco com meu animal de estimação frequentemente.  | 1   |
| 18. I consider my pet to be a great companion.  | 18. Eu considero meu animal de estimação uma grande companhia.   | 1   |
| 19. My pet makes me happy.  | 19. Meu animal de estimação me faz feliz.  | 1   |
| 20. I feel that my pet is part of my family.  | 20. Eu sinto que meu animal de estimação é parte da minha família.   | 1   |
| 21. I am not very attached to my pet.   | 21. Eu não sou muito apegado ao meu animal de estimação.   | 1   |
| 22. I consider my pet to be a friend.   | 22. Eu considero meu animal de estimação como um amigo.  | 1   |
| 23. Owning a pet adds to my happiness.  | 23. Ter um animal de estimação me deixa mais feliz.  | 1   |

**Appendix B. Lexington Attachment to Pets Scale: Versão brasileira (LAPS-B).**

*Instruções*

Os itens que compõem os três fatores do Vínculo com o Animal de Estimação são: 1, 2, 4, 5, 6, 7 e 9 (substituição de pessoas); 3,

8\*, 14, 16, e 20 (direito dos animais); 10, 11, 12, 13, 15, 17, 18, 19, 21\*, 22 e 23 (apego geral). Os itens indicados com um asterisco “\*” devem ter seus escores invertidos antes de serem somados. O somatório de todos os itens de cada subescala indica o nível do Vínculo com o Animal de Estimação. [Table B1](#).

**Table B1**

Brazilian version of the Lexington Attachment to Pets Scale (LAPS-B).

Gostaríamos de saber se você concorda ou discorda com algumas breves afirmações sobre o seu animal de estimação favorito. Por favor, para cada afirmação responda se você discorda totalmente, discorda parcialmente, concorda parcialmente ou concorda totalmente:

0 = Discorda totalmente  
 1 = Discorda parcialmente  
 2 = Concorda parcialmente  
 3 = Concorda totalmente

|  | Concordo totalmente | Concordo parcialmente | Discordo parcialmente | Discordo totalmente |
|--|---------------------|-----------------------|-----------------------|---------------------|
| 1. Meu animal de estimação significa mais para mim do que quaisquer dos meus amigos.   |                     |                       |                       |                     |
| 2. Eu costumo confiar no meu animal de estimação.  |                     |                       |                       |                     |
| 3. Eu acredito que os animais de estimação devem ter os mesmos direitos e privilégios do que membros da família.                 |                     |                       |                       |                     |
| 4. Eu acredito que meu animal de estimação é o meu melhor amigo.   |                     |                       |                       |                     |
| 5. Frequentemente, meus sentimentos em relação às pessoas são afetados pela maneira como elas reagem ao meu animal de estimação. |                     |                       |                       |                     |
| 6. Eu amo o meu animal de estimação porque ele é mais leal a mim do que a maior parte das pessoas em minha vida.                 |                     |                       |                       |                     |

(continued on next page)

**Table B1** (continued)

Gostariamos de saber se você concorda ou discorda com algumas breves afirmações sobre o seu animal de estimação favorito. Por favor, para cada afirmação responda se você discorda totalmente, discorda parcialmente, concorda parcialmente ou concorda totalmente:

0 = Discorda totalmente  
 1 = Discorda parcialmente  
 2 = Concorda parcialmente  
 3 = Concorda totalmente

|   | Concordo totalmente | Concordo parcialmente | Discordo parcialmente | Discordo totalmente |
|---|---------------------|-----------------------|-----------------------|---------------------|
| 7. Eu gosto de mostrar fotos do meu animal de estimação para outras pessoas.    |                     |                       |                       |                     |
| 8. Eu entendo que o meu animal de estimação é apenas um animal de estimação.    |                     |                       |                       |                     |
| 9. Eu amo meu animal de estimação porque ele nunca me julga.                    |                     |                       |                       |                     |
| 10. Meu animal de estimação sente quando eu estou me sentindo mal.              |                     |                       |                       |                     |
| 11. Eu costumo falar com outras pessoas sobre meu animal de estimação.          |                     |                       |                       |                     |
| 12. Meu animal de estimação me entende.   |                     |                       |                       |                     |
| 13. Eu acredito que amar meu animal de estimação me ajuda a me manter saudável. |                     |                       |                       |                     |
| 14. Os animais de estimação merecem o mesmo respeito que os humanos.            |                     |                       |                       |                     |
| 15. Eu e meu animal de estimação temos uma relação muito próxima.               |                     |                       |                       |                     |
| 16. Eu faria quase qualquer coisa para cuidar do meu animal de estimação.       |                     |                       |                       |                     |
| 17. Eu brinco com meu animal de estimação frequentemente.                       |                     |                       |                       |                     |
| 18. Eu considero meu animal de estimação uma grande companhia.                  |                     |                       |                       |                     |
| 19. Meu animal de estimação me faz feliz.                                       |                     |                       |                       |                     |
| 20. Eu sinto que meu animal de estimação é parte da minha família.              |                     |                       |                       |                     |
| 21. Eu não sou muito apegado ao meu animal de estimação.                        |                     |                       |                       |                     |
| 22. Ter um animal de estimação me deixa mais feliz.                             |                     |                       |                       |                     |
| 23. Eu considero meu animal de estimação como um amigo.                         |                     |                       |                       |                     |

## References

- Antonacopoulos, N.M.D., Pychyl, T.A., 2010. An examination of the potential role of pet ownership, human social support and pet attachment in the psychological health of individuals living alone. *Anthrozoös* 23, 37–54.
- Bagley, D.K., Gonsman, V.L., 2005. Pet attachment and personality type. *Anthrozoös* 18, 28–42.
- Brown, T.A., 2015. *Confirmatory Factor Analysis for Applied Research*. Guilford publications, New York.
- DiStefano, C., Morgan, G.B., 2014. A comparison of diagonal weighted least squares robust estimation techniques for ordinal data. *Struct. Equ. Model.* 21, 425–438.
- Hernández, A., Hidalgo, M.D., Hambleton, R.K., Gómez-Benito, J., 2020. International test commission guidelines for test adaptation: a criterion checklist. *Psicothema* 390–398.
- Holcomb, R., Williams, C.R., Richards, P.S., 1985. The elements of attachment: relationship maintenance and intimacy. *J. Delta Soc.* 2, 28–33.
- Hu, L.T., Bentler, P.M., 1999. Cutoff criteria for fit indexes in covariance structure analysis: conventional criteria versus new alternatives. *Struct. Equ. Model.* 6, 1–55.
- Hutz, C.S., Bandeira, D.R., Trentini, C.M., 2015. *Psicometria*. Artmet, Porto Alegre.
- Johnson, T.P., Garrity, T.F., Stallones, L., 1992. Psychometric evaluation of the Lexington Attachment to Pets Scale (LAPS). *Anthrozoös* 5, 160–175.
- Joseph, N., Chandramohan, A.K., D'souza, A.L., Shekar, B., Hariram, S., Nayak, A.H., 2019. Assessment of pet attachment and its relationship with stress and social support among residents in Mangalore city of south India. *J. Vet. Behav.* 34, 1–6.
- Kafer, R., Lago, D., Wamboldt, P., Harrington, F., 1992. The pet relationship scale: replication of psychometric properties in random samples and association with attitudes toward wild animals. *Anthrozoös* 5, 93–105.
- de Fátima Martins, M., Pieruzzi, P.A.P., Santos, J.P.F., Brunetto, M.A., Fruchi, V.M., Ciari, M.B., José da Rocha Luppi, M., Maria de Zoppa, L., 2014. Grau de apego dos proprietários com os animais de companhia segundo a escala Lexington attachment to pets. *Braz. J. Vet. Res. Anim. Sci.* 50, 364.
- Miltiades, H., Shearer, J., 2011. Attachment to pet dogs and depression in rural older adults. *Anthrozoös* 24, 147–154.
- Miranda, M.L.L.A.R., 2011. A importância do vínculo para os donos de cães e gatos nas famílias portuguesas [Master's thesis]. Faculdade de Ciências Biomédicas Abel Salazar, Universidade do Porto.
- Muñiz, J., Elosua, P., Hambleton, R.K., 2013. Directrices para la traducción y adaptación de los tests: segunda edición. *Psicothema* 151–157.
- Poresky, R.H., Hendrix, C., Mosier, J.E., Samuelson, M.L., 1987. The companion animal bonding scale: internal reliability and construct validity. *Psychol. Rep.* 60, 743–746.
- R Core Team, 2020. *R: A Language and Environment for Statistical Computing* (Version 4.0.3) [Computer Software]. R Foundation for Statistical Computing.
- Ramírez, M.T.G., del Carmen Quezada Berumen, L., Hernández, R.L., 2014. Psychometric properties of the Lexington Attachment to Pets Scale: Mexican version (LAPS-M). *Anthrozoös* 27, 351–359.
- Ramos, D., Cruz, N., Ellis, N., Hernandez, J., Reche Junior, A., 2013. Early-stage animal hoarders: are these owners of large numbers of adequately cared for cats? *J. Feline Med. Surg.* 15, 823–824.
- Reevy, G.M., Delgado, M.M., 2015. Are emotionally attached companion animal caregivers conscientious and neurotic? Factors that affect the human–companion animal relationship. *J. Appl. Anim. Welf. Sci.* 18, 239–258.
- Rossee, Y., 2012. lavaan: an R package for structural equation modeling. *J. Stat. Softw.* 48, 1–36.
- Rothgerber, H., Mican, F., 2014. Childhood pet ownership, attachment to pets, and subsequent meat avoidance. The mediating role of empathy toward animals. *Appetite* 79, 11–17.
- Templer, D.L., Salter, C.A., Dickey, S., Baldwin, R., Veleber, D.M., 1981. The construction of a pet attitude scale. *Psychol. Rec.* 31, 343–348.
- Teo, J.T., Thomas, S.J., 2019. Psychological mechanisms predicting wellbeing in pet owners: Rogers' core conditions versus Bowlby's attachment. *Anthrozoös* 32, 399–417.
- Terwee, C.B., Bot, S.D.M., de Boer, M.R., van der Windt, D.A.W.M., Knol, D.L., Dekker, J., Bouter, L.M., de Vet, H.C.W., 2007. Quality criteria were proposed for measurement properties of health status questionnaires. *J. Clin. Epidemiol.* 60, 34–42.
- Urbina, S., 2007. *Fundamentos da testagem psicológica*. Artmed, Porto Alegre.
- Ventura-León, J.L., Caycho-Rodríguez, T., 2017. El coeficiente omega: un método alternativo para la estimación de la confiabilidad. <https://www.redalyc.org/journal/773/77349627039/html/>.
- Wilson, C.C., Netting, F.E., New, J.C., 1987. The pet attitude inventory. *Anthrozoös* 1, 76–84.
- Winefield, H.R., Black, A., Chur-Hansen, A., 2008. Health effects of ownership of and attachment to companion animals in an older population. *Int. J. Behav. Med.* 15, 303–310.
- Zaparanick, T.L., 2008. A confirmatory factor analysis of the Lexington Attachment to Pets Scale [Doctoral dissertation]. Tennessee research and creative exchange, Universidade do Tennessee.
- Zilcha-Mano, S., Mikulincer, M., Shaver, P.R., 2011. An attachment perspective on human–pet relationships: conceptualization and assessment of pet attachment orientations. *J. Res. Pers.* 45, 345–357.