

A Dynamic TDMA-Based Sleep Scheduling to Minimize WSN Energy Consumption

Adelcio Biazi, César Marcon, Fauzi Shubeita, Leticia Poehls, Thais Webber, Fabian Vargas

Pontifícia Universidade Católica do Rio Grande do Sul

Av. Ipiranga, 6681-Prédio 30/BLOCO 4 – 90619-900 – Porto Alegre – RS – BRASIL

{adelcio.biazi, fauzi.shubeita, thais.webber}@acad.pucrs.br, leticia@poehls.com, vargas@computer.org, cesar.marcon@pucrs.br

Abstract—Wireless Sensor Network (WSN) is a communication's architecture composed of several nodes with small power supply, which may be used to monitor hazardous events in inaccessible areas. Thus, on one hand, it is preferable to assure the adoption of the minimum transmission power in order to extend the WSN lifetime, as far as possible. On the other hand, it is crucial to guarantee that the nodes receive the transmitted data correctly. Therefore, trading off power optimization and quality of service has become one of the most important concerns when dealing with modern systems based on WSNs. This paper proposes a new technique based on Time Division Multiple Access (TDMA) focusing on the minimization of energy consumption. The proposed technique adjusts the monitoring timeslot of the sensors according to the environmental changes. The results obtained throughout a WSN simulator show that the implemented technique provides satisfactory results, when compared with classic TDMA techniques. The analyzed scenarios demonstrated improvements regarding the WSN's energy consumption of 17%, in the worst case, and up to 52%, in the most favorable case. The proposed technique reduces the energy consumption of the network and consequently, increases its lifetime.

Keywords— WSN; Energy consumption; TDMA.

I. INTRODUCTION

Wireless Sensor Networks (WSNs) are extensively used in several monitoring and/or control applications. A sensor node collects physical data from environment, then processes data to extract relevant features, stores some of the collected information, and transmits relevant data via wireless connection from one point to another, until reaching a concentrator node in the network. Since normally a sensor node is battery-powered, the minimization of the energy consumption is a major requirement for sensor node design/operation.

Aiming to attain energy efficiency during the WSN operation, several works on the operation and/or the architecture of the local sensor node and/or the global WSN have been proposed in the literature. These works range from optimization of partial circuits to hardware/software joint techniques. In particular, Time Division Multiple Access (TDMA) is a timing share technique that shares the same communication channel employing timeslots for each communicating node. In this context, this paper proposes a TDMA based protocol able to reduce the energy consumption of critical systems, based on the adaptation to the environmental characteristics.

WSN monitoring of critical environments requires fast sensing of data because the information collection and analysis are crucial due to timing constraints. The monitoring of landslides near cities, volcanic eruptions, or a dam, whose

rupture could cause a catastrophic flooding, are just some examples of the application of such system. In these cases, a critical situation never occurs for a long period; there is usually a long stabilization period, which abruptly becomes critical for a short period, then returning to a stable state. Therefore, it is possible to save energy during the periods the environment is stable and use it in periods of emergency.

In the proposed technique, environmental changes can increase or decrease the timeslot employed for sensing and/or computing and transmitting physical data. If the sensed environment remains stable for a long time (i.e., low environmental variations), the energy consumption is reduced transitorily and the saved energy may be employed to fulfill the sensing in the future, when necessary. Consequently, the technique can dynamically adjust the sensing timeslot to minimize the WSN's energy consumption and to avoid loss of data, which is considered fundamental for the system purpose. In other words, the technique consists of adjusting the time in which each sensor node remains in a sleep state. When the environment is stable, the sensor node may spend more time in the sleep state, increasing the timeslot of the TDMA. Oppositely, when the environment variation increases, the frequency of sensing has to be increased to avoid data loss, which means that the frame size of the TDMA has to be reduced.

This paper is organized as follows. Section II contains a discussion about related works. Section III presents the sensor node's architecture regarding the energy consumption. Section III presents the problem formulation. Further, Section V presents the adopted experimental setup while Section VI discusses the obtained results. Finally, Section VII lays out the conclusion and the main contribution of the paper.

II. RELATED WORKS

In literature, there are many hardware and software based techniques aiming at the minimization of the WSN's energy consumption. This section presents those techniques focusing on the energy efficiency challenge throughout the applied communication protocol.

Van Hoesel et al. [1] proposed a medium access protocol called EMACs, which is fully distributed and presents a self-organizing TDMA scheme that extends the network lifetime. The reduction in energy consumption is achieved through the establishment of the appropriate size for the timeslot, which is defined only with local information.

Cho et al. [2] proposed DEE-MAC, which is a dynamic TDMA-based protocol that reduces the energy consumption by making the idle nodes sleep to diminish idle listening. The

technique uses synchronization at Cluster Heads (CHs). The reduction in energy consumption is achieved through an algorithm that allows sending only relevant data to CH, reducing the time of idleness whereas increasing the time of sleep.

Lee, Datta and Cardell-Oliver [3] proposed a TDMA-based protocol named Flexi-MAC, which aims to be fault tolerant and energy efficient. It presents synchronized and flexible slot structure in which nodes build, modify, or extend their scheduled amount of slots based on local information during execution. The authors reduced the energy consumption of the nodes through a distribution of energy-intensive operations across the network.

Xie and Wang [4] proposed EC-TDMA, which is an intra-cluster communication MAC protocol for clustered WSNs. Their proposal is to dynamically change the length of TDMA frames according to the quantity and the traffic load of the sensor nodes within a cluster. According to the authors, the network lifetime is prolonged since the technique reduces the idle listening and improves channel utility.

Sayadi, Mahfoudh and Laouiti [5] proposed the energy-efficient dynamic TDMA and frame size-based MAC protocol named S-OSTR (Sensor One shot Slot TDMA based Reservation). The authors discuss an active period through dynamic frame size that is built slot-by-slot according to nodes arrival in the network. The short frame size obtained combined with an appropriate spatial reuse scheme contributes to significant energy savings according to the authors.

Table 1 summarizes the previously mentioned technique regarding the use of a CH, their ability to adjust the sensing frequency and willingness for employment in critical systems.

TABLE 1. SUMMARY OF RELATED WORKS.

Reference	CH	Sensing frequency	Critical systems support
[1]	No	Low	Low
[2]	Yes	Low	Low
[3]	No	Low	Low
[4]	Yes	High	Moderate
[5]	No	Low	Low
This	Yes	High	High

All works shown in Table 1 have one common goal: to reduce energy consumption by using a TDMA MAC protocol. Approaches [1], as well as [3] and [5] are not appropriate for critical systems, because they are not clustered, which delays the data transport, and increases the node's energy consumption due to the clock synchronization and to the act of informing the new timeslot. Further, although approach [1] enables to change the size of the timeslot, it maintains the TDMA frame length always constant, thus making it impossible to apply to critical systems. The work presented in [3] is also not suitable for critical systems due to its tree structure based topology in data transport. The adapted structure propagates each timeslot data towards the Base Station (BS) at the root of the tree, creating a very high backwardness for leave nodes to reach the BS. As in the [3], work [5] presents a topology problem, because it employs a multiple jump system for the data transport to the BS, becoming unsuitable for critical systems.

The works presented in [2] and [4], despite being clustered, they are not adapted for critical systems. In [2] it is assumed that the system has a very low frequency of data traffic, typically minutes or hours. While [4] measures the size of the frame with greater flexibility, based on the quantity of sensors and on the amount of data load within a cluster, which is excellent for critical systems. However, the use of environmental performance predictions makes it unsuitable for critical systems; i.e. a critical sensor system could be switched off or assigned with a very small timeslot, due to a false prediction.

III. SENSOR NODE ARCHITECTURE AND OPERATION MODES

Figure 1 exemplifies a basic structure of a sensor node with respect to its energy source. The node is composed of: (a) the sensing unit that collects environmental variables; (b) the processing unit, which handles the processing of all the information on the sensor; (c) the storage unit that stores data and code; (d) the timing unit, used to activate processes and to wake up the system; (e) the communication unit that transmits and receives data to/from other sensors.

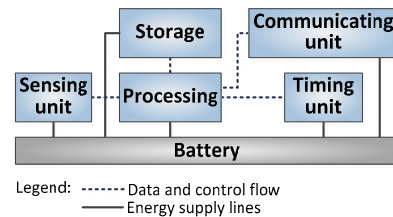

Figure 1. Sensor node architecture.

Figure 2a shows the sensor's architecture in Sleep State, where only the timing unit, which is used to reactivate the system, is consuming energy. Figure 2b displays the sensing unit as active, i.e., in this state, the system collects environment variables and stores it in a buffer memory (storage). Figure 2c presents the activation of the communication unit. In this process, the data is retrieved from the Storage system and sent to the CH. In Figure 2d, the node receives configuration data from the CH. This data is associated with the clock synchronization, the size of the slot, the CH identification (ID), and other data relevant to the system configuration.

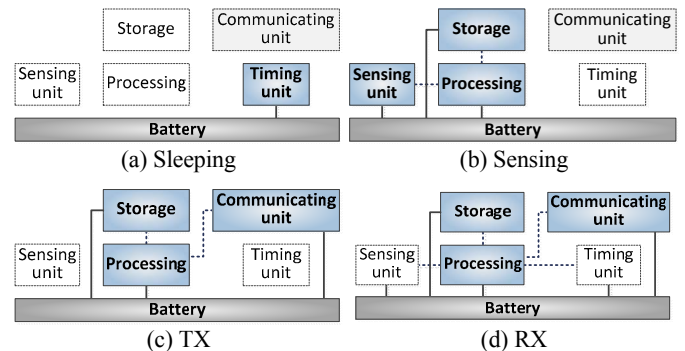

Figure 2. Profile of the node energy consumption according to the node state.

It is important to highlight that the technique proposed in this paper focuses on the communication unit, as it handles approximately 50% of the total energy consumption of the sensor node.

An example of operation scenario of the above model is: “the sensor is sleeping and wakes up after the passage of a certain

time, performs the sensing activity and goes back to the Sleep state". This process is repeated until the node reaches its timeslot. At this point, the data is transmitted (TX) to the CH. After finishing the transmission, the sensor returns to switch with the same frequency between states Sleep and Sensing. At the end of the frame, the CH sets a new scheduling and transmits this schedule to the sensors. Therefore, the sensor node activates the RX state to receive the new settings, as well as the new scheduling and finally, the complete process is repeated.

IV. PROBLEM FORMULATION

Media Access Control (MAC) is the WSN's sublayer that provides addressing and control mechanisms for channel access that make it possible to communicate several nodes in the network. The MAC provides information required in the form of source and destination addresses, which are essential for the successful data transmission and reception.

TDMA is an MAC protocol, where all nodes must transmit data in a period called frame; each node using the protocol has a timeslot to transmit/receive data. TDMA is one of the most commonly used protocols for WSN communication. The basic TDMA operation starts with a cluster of nodes that communicate at a given frequency. The quantity of cluster nodes defines a number of timeslots, and each timeslot is associated with a single node. During the TDMA operation, each cluster node transmits data to the CH using the full bandwidth of the channel during its corresponding timeslot.

It is important to highlight that only one sensor node is transmitting data during each timeslot. Therefore, the remaining nodes can go into the Sleep State, turning off the most energy consuming components. Thus, according to the quantity of nodes and to the size of each timeslot, the node remains in Sleep state reducing their energy consumption significantly. It has to be pointed out that data transmission and reception are the most energy-consuming tasks of the WSN operation.

In the TDMA-based algorithm proposed in this paper, all sensor nodes transmit data following a schedule and having the same timeslot during a given frame. However, depending on the system's criticality, in a future frame the timeslot may increase or decrease. In other words, environmental changes affect the node's operation frequency. In addition, not always node has data to be transmitted during their timeslot, since it depends on changes in the sensing variables, enabling to reduce the frequency of monitoring. This reduction can be achieved by increasing the timeslot size, which consequently increases the probability of finding a significant variation. Note that, if the sensing circuit remains turned on, eventual system changes may be stored even in periods where the node is not transmitting. Applying TDMA protocols to critical systems imply several trade-offs in the energy consumption policy. For instance, (i) reducing the timeslot size increases the sensing frequency, and consequently, it minimizes the possibility of data losses during the period the sensor is in Sleep state; (ii) increasing the timeslot size remaining in the Sleep state may lose some environmental changes; (iii) applying the same operation model of (ii), but turning the sensing circuit on implies turning the processing and memory circuit on, to store possible environment variations, increasing the energy consumption. Therefore, the increase of active components during the stand-by state increases the energy

consumption, and the data transmission may require more time to transmit eventual data variations. However, the increase of the timeslot does not imply more energy consumption during the timeslot interval, because the sensor node may sleep as soon as it finishes its data transmission, even remaining inside the timeslot interval.

If there is a high degree of environmental variation, the timeslot needs to be reduced because a critical situation is occurring, and the highest quantity of sensors needs to be prompted to obtain a trustworthy result. Thus, the entire system is monitored more frequently, increasing the overall energy consumption.

Figure 3 presents the TDMA scheduling, where each frame is composed of M timeslots, and each timeslot can deliver K packets. The lines that connect CH to the timeslot (such that $0 \leq i < M$) indicate that each node has only one timeslot, and exchanges data with the CH node in such interval, exclusively.

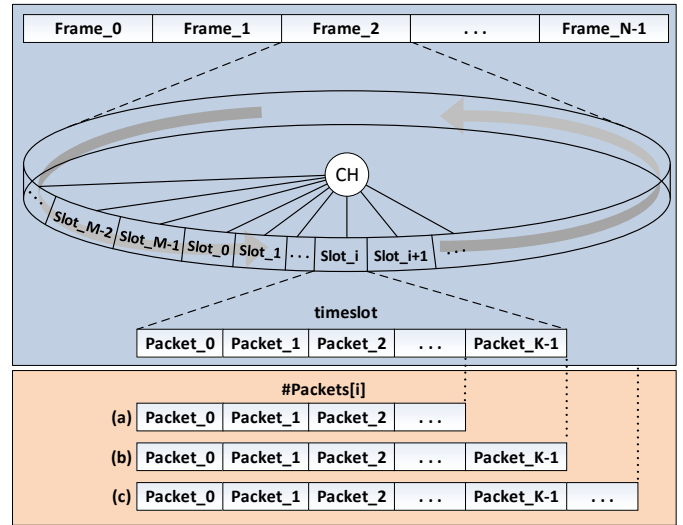

Figure 3. TDMA scheduling model, and quantity of packets stored to be transmitted in each timeslot.

Additionally, each i^{th} sensor node stores, in its local Storage unit, some quantity of packets ($\#Packets[i]$) according to its environmental monitoring. However, $\#Packets[i]$ could be different from the size of the timeslot, implying that the i^{th} sensor node has dissimilar communication requirement. Figure 3 shows the three possible situations: (a) $\#Packets[i] < \text{timeslot}$, (b) $\#Packets[i] = \text{timeslot}$, and (c) $\#Packets[i] > \text{timeslot}$, meaning that the timeslot is overestimated, appropriated and underestimated for communication requirements of the i^{th} sensor node, and according to these three situations, the timeslot may be increased, maintained or decreased, respectively.

The technique to increase or decrease the timeslot is given by the harmonic mean; we choose harmonic mean because this criterion accepts the gradual and balanced variation between sensors of the network, represented by Equation 1.

$$H = \frac{M}{\sum_{i=0}^M \frac{1}{X_i}} \quad (1)$$

H is the harmonic mean; M is the quantity of sensor nodes; x_i is the i^{th} timeslot that did not send packets, such that the sum of all x_i computes the total empty timeslots. Besides using the harmonic mean, the following criteria must be established:

- If the total amount of packets to be transmitted is equal to the size of the timeslot, the size of the timeslots of the next frame is not changed;
- Division by zero is considered zero;
- A criterion to stop the increase or decrease of the timeslot should be considered because the increase may tend towards infinity. Thus, a minimum and a maximum timeslot should be defined according to the application characteristics;
- If $H > 1$, then the timeslot increases with the integer part of H . For instance, if $H = 4.7$ then $timeslot = timeslot + 4$; because the value is positive because little variation in the environment has taken place, and the timeslot. Therefore, should be increased to allow more time for sleep. The greater the value of H the greater is the system's stability.
- If $0 < H \leq 1$, then the timeslot decreases with the first decimal value. For instance, if $H = 0.6$ then $timeslot = timeslot - 6$, i.e., there is a wide variation in the environment and the frequency of collection should be increased. The smaller the value of H , the higher is the amount of data a sensor sends to the CH.
- If $H \leq 0$, then the timeslot remains the same.

Figure 4 presents the algorithm that computes the size of the timeslot employing the above criteria.

V. EXPERIMENTAL SETUP

Figure 5 presents the experimental setup used to evaluate the proposed algorithm. Firstly, the flow creates M sensors nodes and one CH. The sensor nodes receive basic settings, such as radio frequency and the rate of collection of environmental variables. The CH is configured to receive/transmit data from/to

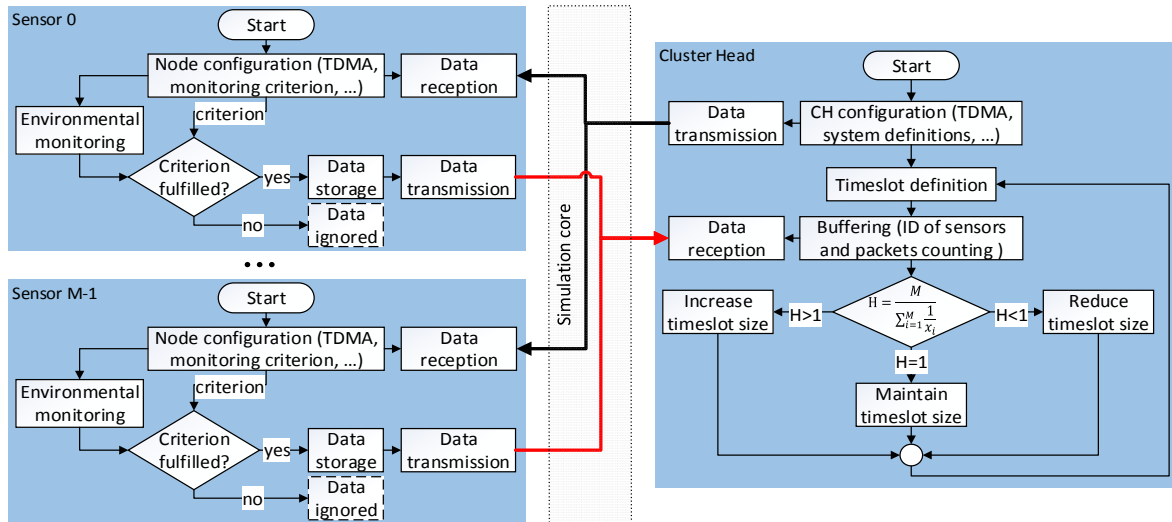

Figure 5. Experimental setup.

```

1  double div ← 0.0, med ← 0.0, aux;
2  for(int i ← 0; i < M; i++) {
3      aux ← timeslot - #Packets[i];
4      if(aux == 0.0)
5          div ← 1.0;
6      else if(aux < 0.0)
7          div ← 1 + (aux * -1);
8      else
9          div ← 1 / aux;
10     med ← med + div;
11 }
12 if(med == 0)
13     return 0;
14 double H ← M / med;
15 if(H < 1.0)
16     return (int)Math.round((H - (int)H) * 10) - 1
17     return (int)H;

```

Figure 4. Algorithm that calculates the timeslot of each TDMA round

the sensor nodes according to the TDMA-based algorithm. This configuration is set after an initial definition of the size of the timeslot, and then this size, together with the corresponding schedule for each sensor and their time synchronization, are sent to each sensor.

The WiNeS Simulator, presented in [6], manages the communication between sensor nodes and CH. WiNeS is a WSN simulator that supports discrete events, synchronous and asynchronous models. It also provides an environment for a variety of simulation models, allowing the use of any network topology, protocol or type of sensor node.

VI. EXPERIMENTAL RESULTS AND DISCUSSIONS

Three test scenarios enable to evaluate and validate this work, which correspond to stable systems with homogeneous environmental parameters; i.e., the same type of sensing, and all measures have low changes. However, at a given time, any system can become critical, and the monitoring should be highly controlled.

A. Scenario A

The first scenario concerns the monitoring of soil humidity, where landslides may occur during periods of very heavy rainfall. This phenomenon handles disasters that have taken away countless lives. For instance, the landslide in Rio de

Janeiro, Brazil in 2010, causing about 250 deaths and the need for a substantial financial investment. Also, the landslide in Afghanistan in 2014, leaving at least 350 dead.

Typically, in this scenario the soil has stable moisture for a long period, allowing to reduce the monitoring frequency by increasing the timeslot. Consequently, increasing the time that each sensor node stays in the Sleep state reduces the energy consumption. Additionally, when a sensor node is scheduled, few data is sent to the CH since the environment has small or no variation, which reduces the energy consumption yet more. However, during a rainfall period the monitoring needs to be intensified, which is performed reducing the timeslot to increase the frequency in which each sensor node sends data to the CH. Therefore, the period that the sensor nodes remain sleeping is reduced, increasing the energy consumption.

Figure 6 shows three curves containing the energy consumption for three different approaches: (a) the continuous line represents a classic TDMA that sends all possible data with an invariable timeslot; (b) the dashed line denotes the energy consumption when applying a criterion for data selection, i.e., sending only relevant data. In this specific scenario, the criterion is more than 60% of moisture in the soil; and (c) the dotted line represents the energy consumption when using a TDMA with a flexible timeslot. The dashed and dotted lines have the same criterion for data selection. It is remarkable that the largest leap regarding energy consumption is related to the data selection criterion when compared to a classic TDMA that sends all data. However, there is a significant additional reduction in energy when applying a flexible timeslot size.

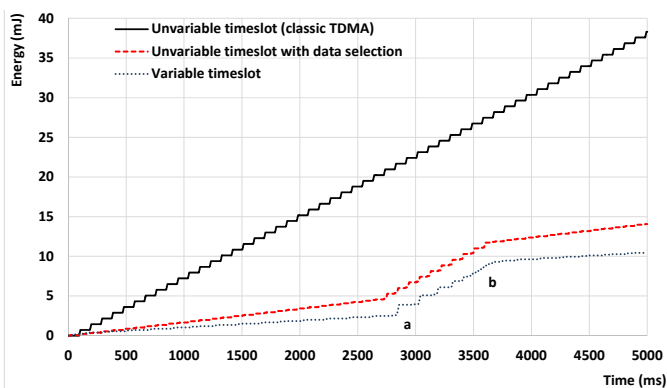

Figure 6. The arithmetic average of five simulations of one of the ten-soil humidity sensors. The energy consumption corresponds to the values of HOBOnode soil moisture wireless sensor with 2.4 GHz frequency [8].

Figure 6 shows that the classic TDMA presents a ramp in a ladder format, which means practically constant energy consumption; i.e., the horizontal and inclined segments represent the energy consumption during the Sleep and Transmitting states, respectively. For the remaining two approaches, the energy consumption follows a straight biased line, indicating a constant consumption, but at a certain point, an acceleration of energy consumption is observed. At a later point, the constant consumption behavior returns, which can be explained by the fact that a critical value is identified. Consequently, the control is intensified, increasing the amount of data sent to the CH and reducing the sleep time of each node.

The letters "a" and "b" of Figure 6 identify the worst and the best case of latency, respectively. The worst case occurs when the system is stable; consequently using a large timeslot and abruptly entering into a critical situation, hence, requiring to increase the monitoring frequency. In this case, the system is penalized with the period of one frame (timeslot multiplied by the number of sensors) before starting to react with the new higher frequency. The best case occurs when the system leaves the critical state, enabling to reduce the monitoring frequency. As a result, the delay for increasing and decreasing the timeslot makes the system to be unsuitable for real-time systems.

B. Scenario B

Some environments require stable ambient temperature. An example could be an integrated circuits factory floor. Usually, these environments are hermetically sealed with access of personal and objects. However, at a given time, employees and/or objects enter/leave in/from the environment. At this time, a WSN associated to the temperature actuator can be used to monitor and to control the temperature, minimizing its variation.

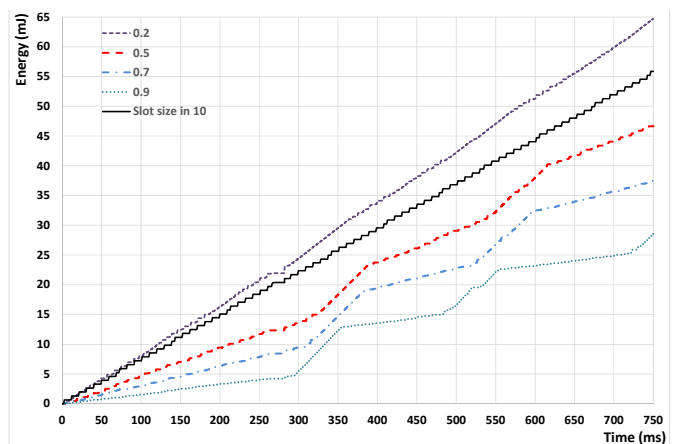

Figure 7. Arithmetic average of energy consumption for five simulations of one of ten temperature sensor (0.2 is the lowest tolerance therefore transmit more data for CH). The consumption corresponding to the values of CC2500 2.4GHz frequency with MSP430 microcontroller [8].

Figure 7 shows the energy consumption of the system for different tolerances of temperature variation (i.e., 0.2°C, 0.5°C, 0.7°C and 0.9°C). The figure represents a time interval where the temperature is stable most of the time, with temperature variation due to the entrance of people during the morning and then, a partial exit of people at noon and their corresponding return. This particular system requires a stable temperature at 20°C, with 0.5°C of tolerance, for example, i.e., the system tolerates temperatures in the range between 19.5°C and 20.5°C. This tolerance causes a hysteresis that minimizes the amount of data to be transmitted since any sensor node only sends data that is outside this tolerance range. Therefore, increasing tolerance decreases the amount of data to be transmitted. Additionally, an approach with fixed timeslot is presented.

The WSN's energy consumption reduces with the increase of the temperature variation tolerance since higher tolerance reduces the amount of data transmitted and increases the time that each sensor remains in Sleep state. In particular, comparing the dotted line with the continuous line, we have noticed that when the temperature tolerance is very small the energy consumption is even higher than for the situation with a fixed

timeslot. This behavior is explained by the short time each sensor stays in the Sleep state.

C. Scenario C

Figure 8 shows the volcanic activity of Gorgona Isla. The data was captured on Feb. 11, 2015, by the seismographic network SEISAN [9].

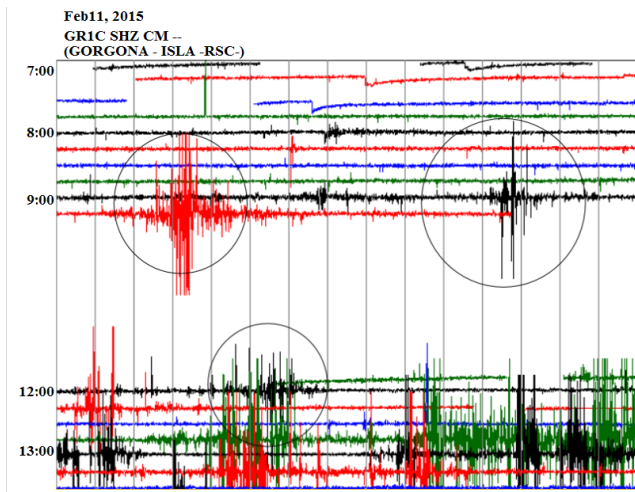

Figure 8. Graphical representation of a volcanic seismograph.

This experiment encompasses the interval between 08:00 and 13:30, highlighting three volcanic activities identified by circles. Figure 9 shows the energy consumption of this experiment, where each interval of the energy consumption increasing corresponds to the critical events identified by a circle in Figure 8.

It is evident that the TDMA fixed timeslot has higher energy consumption when compared to the adaptive approach. Furthermore, the adaptive approach enables to increase the interval the node remains sleeping, because there is slight variation in collected variables, as in the case of the region not circled (i.e., from the range of 7 to 9 hours).

VII. FINAL CONSIDERATIONS

This paper proposes a TDMA-based algorithm that minimizes WSN’s energy consumption and consequently enlarges the system lifetime. Additionally, the algorithm reacts

quickly to environment changes, enabling its adoption to critical environment monitoring. Therefore, the proposed technique has proven to be suitable for long monitoring/control time of scenarios with low but critical environmental changes. It is important to mention that this TDMA-based algorithm is not applicable in scenarios where the environment remains constant; because, without environmental variation, the timeslot size remains static and the advantages of the proposed algorithm cannot be perceived. Further examples for scenarios where the proposed approach is not suitable are those where the variation lasts less than the system latency.

An interesting advantage of this new algorithm is the WSN capability of increasing the sensing frequency during critical situations, where the environmental characteristics change significantly.

REFERENCES

- [1] L. van Hoesel et al. Advantages of a TDMA based, energy-efficient, self-organizing MAC protocol for WSNs. *IEEE Vehicular Technology Conference (VTC)*, pp.1598-1602, 2004.
- [2] S. Cho et al. Dynamic Energy Efficient TDMA-based MAC Protocol for Wireless Sensor Networks. *Joint International Conference on Automatic and Autonomous Systems and International Conference on Networking and Services (ICAS-ICNS)*, pp.48-52, 2005.
- [3] W. Lee, at all FlexiMAC: A flexible TDMA-based MAC protocol for fault-tolerant and energy-efficient wireless sensor networks. *IEEE International Conference on Networks (ICON)*, pp.1-6, 2006.
- [4] M. Xie, X. Wang. An Energy-Efficient TDMA Protocol for Clustered Wireless Sensor Networks. *ISECS International Colloquium on Computing, Communication, Control, and Management (CCCM)*, pp.547-551, 2008.
- [5] A. Sayadi, S. Mahfoudh, A. Laouiti. Sensor-OSTR: Novel energy-efficient dynamic TDMA frame size-based MAC protocol for wireless multi-hop sensor networks. *IFIP Wireless Days (WD)*, pp.1-3, 2012.
- [6] V. Bohrer et al. A flexible framework for modeling and simulation of multipurpose wireless networks. *International Symposium on Rapid System Prototyping (RSP)*, pp.94-100, 2013.
- [7] M. Joordens et al. Conceptual design for fully autonomous aerial and ground system for precision agriculture. *IEEE System of Systems Engineering Conference (SoSE)*, p.99-104, 2015.
- [8] Texas Instruments, eZ430-RF2500 development Tool. Available: <http://www.ti.com/>, 2009. Accessed on: March, 7, 2016.
- [9] National Seismological Network of Colombia. Available: <http://seisan.sgc.gov.co/RSNC/>. Accessed on: March, 7, 2016.
- [10] Tmote Sky, Ultra low power IEEE 802.15.4 compliant wireless sensor module. Datasheet. Available: <http://www.seas.harvard.edu/>. Accessed on: March, 7, 2016.

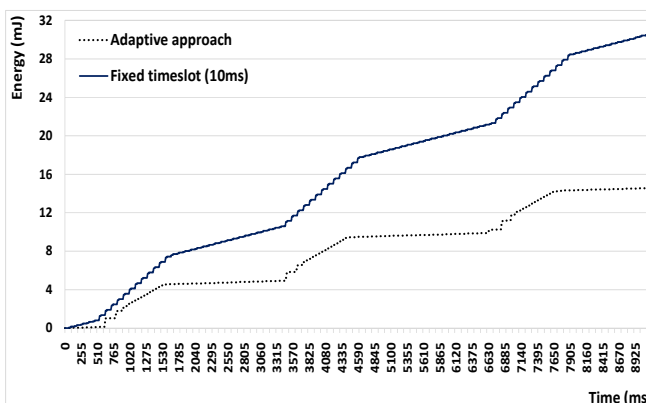

Figure 9. The arithmetic average of energy consumption for five simulations of one of ten seismic sensors. The energy consumption corresponds to the values of TMote Sky wireless sensor with the CC2420 radio operating at 2.4 GHz and MSP430F1611 microprocessor [10].